



JCB VIBROMAX – COMPACTION EQUIPMENT
TOW-TYPE VIBRATORY ROLLER VM651/VM651PD



OPERATING WEIGHT:

6300kg / 6500kg

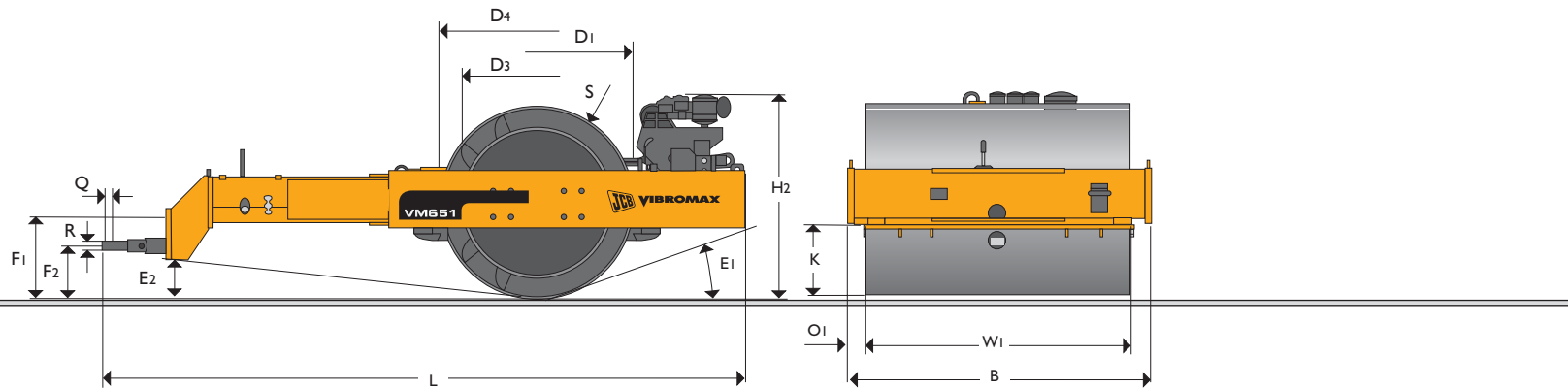

STATIC DIMENSIONS

Dimensions in millimetres (in)		
B	Overall width	2250 (88.5)
D1	Drum diameter	1500 (59.0)
D3	Drum diameter for PD	1080 (42.5)
F1	Height of towing eye, upper position	630 (24.8)
F2	Height of towing eye, lower position	430 (16.9)
H2	Overall height	1725 (67.9)
K	Ground clearance	550 (21.66)
L	Total travel length	4550 (179.1)
O1	Overhang left and right	75 (2.9)
Q	Diameter of towing eye	50 (1.9)
R	Thickness of towing eye	46 (1.8)
S	Drum thickness	25 (0.9)
W1	Drum width	2100 (82.73)
E1	Departure angle rear	20°
E2	Departure angle front	8°

OPERATING DATA

Operating weight (CECE)	kg	6300 / 6500
Operating linear load	kg/cm	30
Exciter frequency	Hz	40 / 40
Nominal amplitude	mm	1.35 / 1.35
Centrifugal force	kN	210 / 210
Centrifugal force / drum width	N/cm	1.000
Compaction depth up to	cm	80 / 100



JCB VIBROMAX – COMPACTION EQUIPMENT TOW-TYPE VIBRATORY ROLLER VM651/VM651PD



ENGINE

Three-cylinder, air and oil-cooled, four-stroke Diesel engine.

Make		Deutz
Model		F 3 L 914
Piston displacement	cm ³	3240
Performance – DIN 6271	kW / HP	42 / 57
Operating speed	rpm	2500
Starting device		Electric motor
Air cleaner		Oil bath air cleaner
Fuel filter		Cartridge
Fuel consumption	l/h	8.2

PROPULSION

Towing tractor.

EXCITER DRIVE

Electrically controlled hydrostatic direct drive.

EXCITER

Single-shaft circular exciter.

FEATURES

- Hydrostatic exciter drive
- Electric starter
- Optimal weight balance
- Interchangeable smooth and sheepfoot drum

ELECTRICAL SYSTEM

Voltage	V	12
Battery capacity	Ah	88
Alternator	V(A)	14 (33 maximum)

SERVICE CAPACITIES

Fuel	litres	120
Engine oil (engine)	litres	8
Gear oil (exciter)	litres	20
Hydraulic oil	litres	140

INDICATORS

Hour meter.

REQUIREMENTS FOR TOWING THE UNIT

Minimum travel speed	km/h	1.8 / 2.4
Minimum engine performance (DIN 6271)	kW (hp)	37 (50) / 51 (70)
Minimum operating weight for wheel driven units	kg	6500 / 8650
Minimum operating weight for crawler driven units	kg	4900 / 6500

SHEEPSFOOT DRUM

Number of sheepfeet		120
Height of each foot	mm	210
Number of contact feet		12
Centrifugal force per contact foot	kN	17.5



JCB Vibromax Compaction Equipment GmbH, PO Box 230149, 40087 Düsseldorf, Germany, Erkrather Straße 343, 40231 Düsseldorf, Germany. Tel: +49 (0) 2 11 - 9 86 63. Fax: +49 (0) 2 11 - 9 86 65 55. Web: <http://www.jcbvibromax.de>

JCB Vibromax America Inc, 2823 Carlisle-Avenue, Racine, WI, 53404, USA. Tel: +1 262-637-8111. Fax: +1 262-637-8211.

JCB Vibromax Singapore, Representative Office, 72 Pasir Ris Heights, Singapore 519279. Tel: +65 6583 8297. Tel: +65 6583 8301.

JCB cares for the environment. This paper has been produced without the use of elemental chlorine chemicals in the bleaching process.

JCB reserves the right to change specifications without notice. Illustrations shown may include optional equipment and accessories. The JCB logo is a registered trademark of J C Bamford Excavators Ltd.



9999/5162 11/06 Issue 2

A Product
of Hard Work